

HFI 32

Integrated Synchronous Servo Drive

positioning capability
various field bus systems
functional safety STO
up to 440 Watts rated output power
with or without parking brake

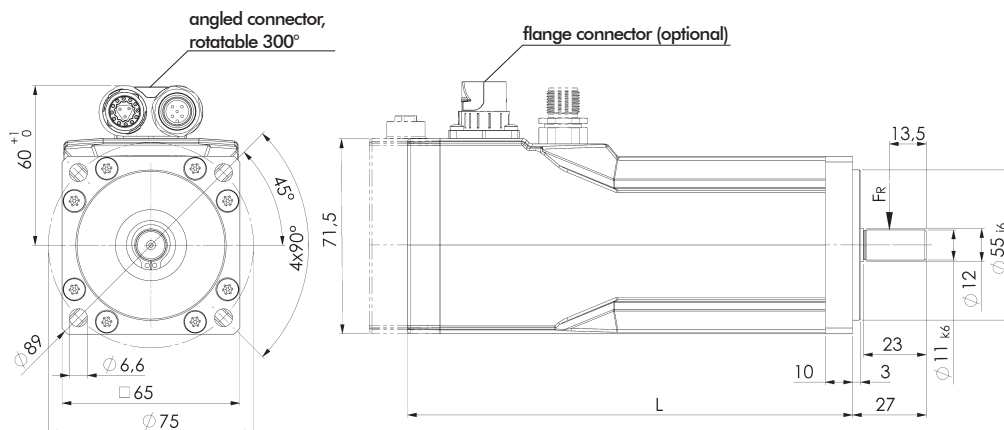
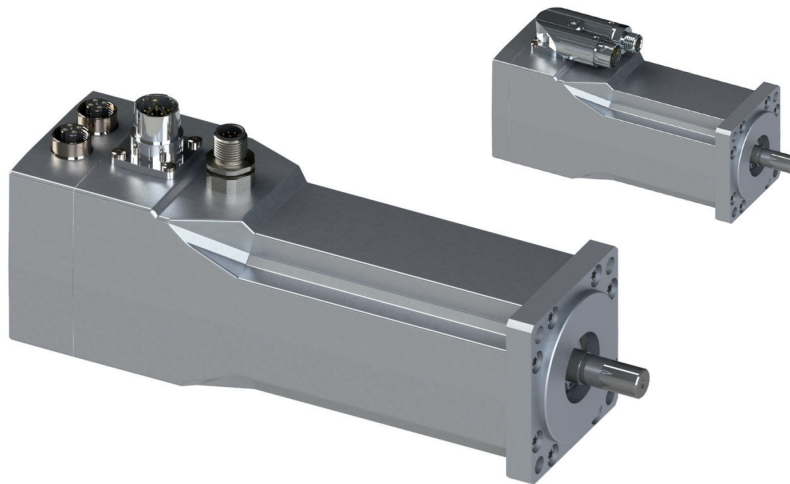

Motor type	Dimension L
HFI3260-XX00	163
HFI3260-XX00-HB	193
HFI3290-XX00	193
HFI3290-XX00-HB	223

(With optional fieldbus module the dimension L1 will be 14mm longer.)

Operation characteristics:

Measured at 24VDC

HFI 3260, 48V, 3000/4000rpm

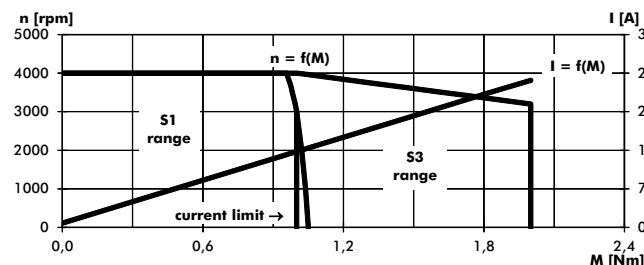

HFI 3290, 48V, 3000/4000rpm

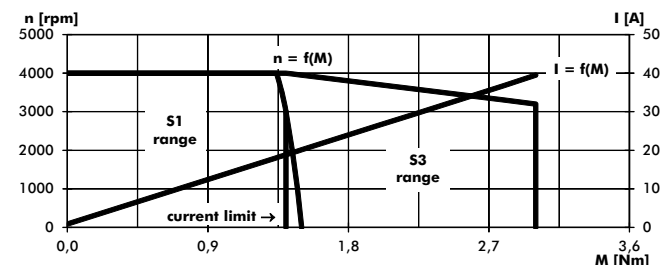

Description:

Synchronous Servo Drives with powerful concentrated winding motor systems and integrated electronics for operation at selective 24VDC (only HFI 3260) or 48VDC.

These very compact and powerful drives are well suited for peripheral application in single or multi axes systems.

The HFIs are operated either by analogue/digital signals or via the CANopen interface. By means of an optional fieldbus module, the devices can be integrated into common, Ethernet-based fieldbuses.

The fieldbus interfaces provides profile torque mode, profile velocity mode and profile position mode as well with either linear or jerk free velocity ramps.

The profile position mode supports absolute and relative target-settings. Homing is done onto limit switches, mechanical stop or at the current position.

The rotor position is evaluated through a linear magnetic angle sensor system. The sinusoidal motor current leads to smooth and constant torque development.

Optionally the drives are available with functional safety „STO“ according to Performance-Level [e], cat. 3; SIL-3.

The electrical connection is done through a compact single or dual rotary connector depending on the drive version; with optional fieldbus module and/or STO via radially arranged flange connectors.

The drive's configuration is done via RS232 and a clear and easy to use PC-Software „DSerV“ (included).

Features:

- Peripheral operation, less effort to install
- Stand alone operation with analogue speed setpoint
- Compact and powerful
- Positioning capability
- Protection class IP54 (IP65 as an option)

Options:

- Several fieldbuses: CANopen, EtherCAT, PROFINET, EtherNet/IP
- Functional safety STO (Safe Torque Off)
- 1-/2-stage planetary gear
- Parking brake
- Customer-specific solutions

edition 10.20

HFI 32

		HFI 3260	HFI 3290	
type		-	-	
series		-	-	
max. speed	rpm	4000	4000	
bus voltage	VDC	24 / 48	48	± 20%
nominal speed	rpm	2600 / 3000	3000	
nominal current ²⁾	ADC	14,0 / 8,0	10,8	
nominal power ^{2)*)}	W	260 / 315	440	
operation acc. to VDE 0530		S1		
protection acc. to VDE 0530		IP 54		
rotating direction		reversible		
structural shape acc. to VDE 0530		IM B5 - with alignment by end plate		
kind of connection		connectors (see below)		
mechanical data:				
moment of inertia motor	kgm ²	0,048*10 ⁻³	0,063*10 ⁻³	
nominal torque ^{2)*)}	Nm	0,95 / 1,0	1,4	
peak torque ^{*)}	Nm	2,0	3,0	
speed regulation constant	N ⁻¹ cm ⁻¹ rpm	2,6	1,6	
mechanical time constant	ms	1,5	1,3	
friction torque	Nm	0,06	0,07	
rotor weight	kg	0,46	0,62	
total weight	kg	2,1	2,7	
ball bearings	A/B-side	6201/6200	6201/6200	
F _R (allowable radial shaft load) ³⁾	N	100	100	
F _A (allowable axial shaft load)	N	40	40	
electrical data:				
number of phases		3	3	
number of poles		6	6	
terminal resistance ⁴⁾	Ω	0,05 / 0,18	0,12	
inductance ⁴⁾	mH	0,07 / 0,25	0,22	
voltage constant ^{1)*)}	V/1000 rpm	4,8 / 9,3	9,4	
torque constant ^{1)*)}	Nm/A	0,040 / 0,077	0,078	
electrical time constant	ms	1,4	1,8	
thermal data:				
ambient temperature range	°C	0 ... 40	0 ... 40	
isolation acc. to VDE 0530		F	F	
thermal time constant	min	20	25	
temperature-rise n.v.	K/W	0,65	0,63	
parking brake:				
static brake torque	Nm	3,5	3,5	automatically activated
power	W	12	12	
mass moment of inertia	kgm ²	0,018*10 ⁻³	0,018*10 ⁻³	
motor weight incl. parking brake	kg	2,4	3,0	
signal interfaces:				
analogue input ⁵⁾	AE1	± 10V, 12Bit, Ri=22kOhm		setpoint setting
digital inputs ⁵⁾	DE1 ... DE8	0,0V ≤ U _{off} ≤ 5,0V 15,0V ≤ U _{on} ≤ 30V		DE1 = enable DE2 ... 8 = function partly configurable
digital outputs ⁵⁾	DA1 DA2	24V, 50mA, o.C.		function configurable e.g. ready, speed indication...
serial interfaces	RS232	max. 115200Baud		for „DSeV“ software communication
	(optionally) CANopen	max. 1Mbit/s, ISO11898		
	(optionally) field bus	EtherCAT, PROFINET, EtherNet/IP		Ethernet-based
	(optionally) safety	Safe Torque Off (STO)		acc. to Performance-Level [e], cat. 3; SIL-3
connectors:				
angled connector, rotatable 300°		Serie 915 itec (INTERCONTEC)		power + I/O + RS232
angled connector, rotatable 300°	(optionally)	Serie 615/915 ytec (INTERCONTEC)		power + I/O + RS232 + CANopen
flange connector	Motor (optionally)	series 915 connector, 15-pol. (INTERCONTEC)		power + I/O + RS232
	field bus (optionally)	2 x M12 socket, 4-pole, D coded		fieldbus 1 + fieldbus 2
	safety (optionally)	M12 plug, 8-pole, A coded		STO

*) Tolerance -10 %

¹⁾ Sinusoidal-peak

²⁾ Values are valid for a drive mounted to an aluminium panel (heat sink) of at least 0,15 m² at a thickness of 10 mm. For versions with gearbox, with integrated parking brake or with radial shaft seal the values are reduced.

³⁾ Center of the shaft-extension.

⁴⁾ Measured between two phases.

⁵⁾ Selective functions: AE1 ↔ DE6, DA1 ↔ DE5, DA2 ↔ DE4.

order code:

HFI32XX-XXXX-XX-...-XX

HB = parking brake, GP = planetary gear,
CO = CANopen, EC = EtherCAT
PN = PROFINET, EI = EtherNet/IP

00 = standard version
XX = customized version

2 = 24VDC operation voltage
4 = 48VDC operation voltage

S = functional safety STO
N = non safety

60 = HFI 3260
90 = HFI 3290

Accessories (optional):

- supply / signals cable assembled 2m / 5m
- CAN cable assembled 6m
- fieldbus cable assembled 5m
- STO cable assembled 5m

HFI 32

hybrid connector for power + I/O + RS232

signals: power supply 24/48VDC
digital/analogue inputs/outputs
serial interface RS232

connector: hybrid plug series 915
15-pole (12+3) (INTERCONTEC)

connector 15-pole
series 915



connecting side
of connector

pin assignment

- A - +Ub
- B - 0V
- C - +Ubl
- 1 - DE1
- 2 - DE2
- 3 - DE3
- 4 - DA1/DE5
- 5 - DA2/DE4
- 6 - AE1+
- 7 - AE1-/DE6
- 8 - GND
- 9 - DE7
- 10 - TxD
- 11 - RxD
- 12 - DE8

field bus options

CANopen®:

profiles: CiA 301
CiA 402 drive profile

interface: galvanically isolated

connector: M12 plug 5-pole, A coded

M12 plug
5-pole, A coded

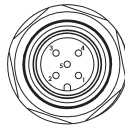

connecting side
of connector

pin assignment

- 1 - CAN_SHLD
- 2 - free
- 3 - CAN_GND
- 4 - CAN_H
- 5 - CAN_L

EtherCAT (fieldbus module):

profiles: CANopen over EtherCAT (CoE)
CiA 402 drive profile

status indicators: 2 x LEDs
Module Status, Network Status

features: Integrated 2-Port-Switch

connector: 2 x M12 socket 4-pole, D coded

M12 socket
4-pole, D coded

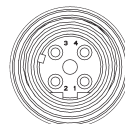

connecting side
of connector

pin assignment

- 1 - TX+
- 2 - RX+
- 3 - TX-
- 4 - RX-

recommended cable type Cat.5e (min.)

PROFINET (fieldbus module):

profiles: PROFINET Conformance
Class A, B and C
PROFIDRIVE

status indicators: 2 x LEDs
Module Status, Network Status

features: Integrated PROFINET IRT Switch

connector: 2 x M12 socket 4-pole, D coded

M12 socket
4-pole, D coded

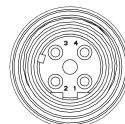

connecting side
of connector

pin assignment

- 1 - TX+
- 2 - RX+
- 3 - TX-
- 4 - RX-

recommended cable type Cat.5e (min.)

EtherNet/IP (fieldbus module):

profile: Generic (CIP)

status indicators: 2 x LEDs
Module Status, Network Status

features: Integrated 2-Port-Switch

connector: 2 x M12 socket 4-pole, D coded

M12 socket
4-pole, D coded

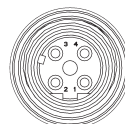

connecting side
of connector

pin assignment

- 1 - TX+
- 2 - RX+
- 3 - TX-
- 4 - RX-

recommended cable type Cat.5e (min.)

option Safe Torque Off (STO)

certifications:
- SIL-3 acc. to EN 61508, EN 62061
- Performance-Level [e], Category 3 acc. to EN ISO 13849-1

supply: 20,4 ... 28,8 VDC / max. 30 mA

connector: M12 plug 8-pole, A coded

M12 plug
8-pole, A coded

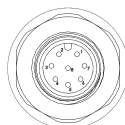

connecting side
of connector

pin assignment

- 1 - Status+
- 2 - Status-
- 3 - STO1-
- 4 - STO1+
- 5 - free
- 6 - STO2+
- 7 - STO2-
- 8 - free

standard configuration

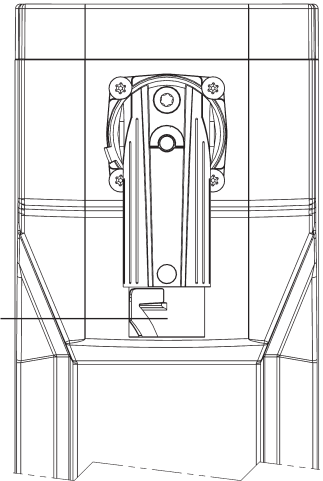

1

with option CANopen

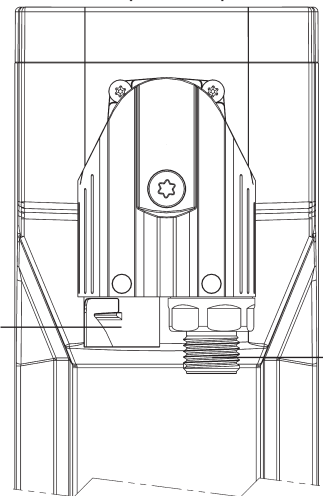

1

2

with option fieldbus and/or STO

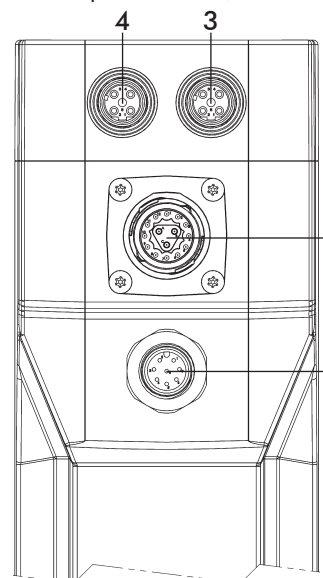

4

3

1

5

connectors:

- 1 power + I/O + RS232
- 2 CANopen
- 3 fieldbus 1 (in)
- 4 fieldbus 2 (out)
- 5 STO