

HBI 22

Integrated Synchronous Servo Drive

positioning capability
up to 90 Watts rated output power
with linear hall sensor system
with or without parking brake

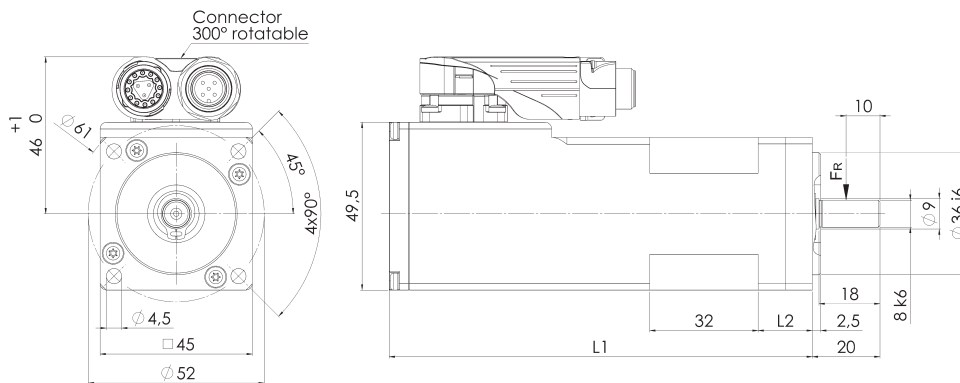
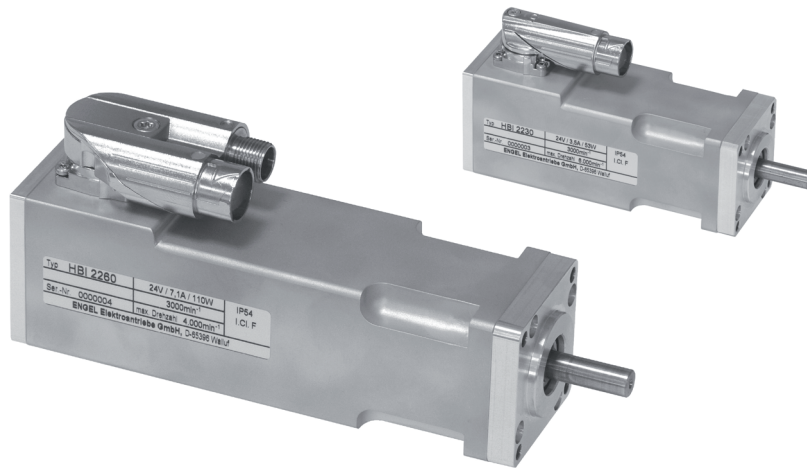

Motor type	Dimension	
	L1	L2
HBI 2230	125	15
HBI 2230-B7.01	157	17
HBI 2260	155	15
HBI 2260-B7.01	187	17

Operation characteristics:

Measured at 24VDC

HBI 2230, 24V, 3000/6000rpm

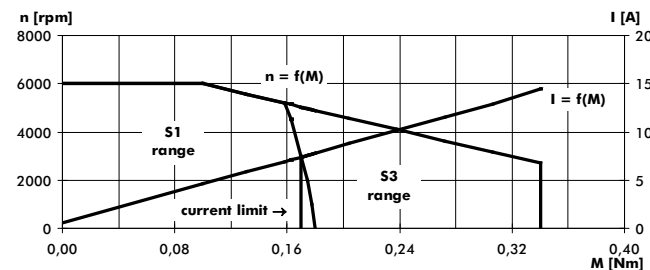

HBI 2260, 24V, 3000/4000rpm

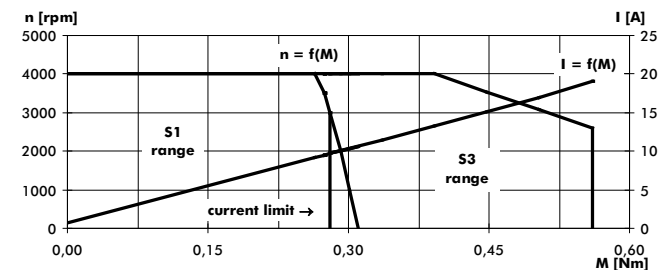

Description:

Brushless Synchronous Servo Drives with powerful concentrated winding motor systems and integrated electronics for operation at selective 24VDC or 48VDC.

With their powerful and pleasing „motor only“ design these compact drives are well suited for peripheral application in single or multi axes systems.

The HBI's are operated either by analogue/digital signals or via the CAN interface that supports CANopen as a standard and DeviceNet as an option.

The CANopen interface provides profile torque mode, profile velocity mode and profile position mode as well with either linear or jerk free velocity ramps.

The profile position mode supports absolute and relative demands. Homing is done onto limit switches, mechanical stop or at the current position.

The rotor position is evaluated through a linear hall sensor system. The sinusoidal motor current feed leads to smooth and constant torque development.

A rotatable angled connector feeds both power supply and signals to the HBI. Executions supporting CAN and incremental signals are equipped with an additional M12 connector.

The drives configuration is done via RS232 and a clear and simple to use PC-Software „DserV“.

Features:

- Peripheral operation, less effort to install
- Stand alone operation with analogue speed setpoint
- Compact and powerful
- Positioning capability
- Protection class IP54 (IP65 as an option)

Options:

- DeviceNet
- 1-/2-stage planetary gear
- Parking brake
- Customized executions

HBI 22

		HBI 2230	HBI 2260	
type series		-	-	
max. speed	rpm	6000	4000	
bus voltage	VDC	24 / 48	24 / 48	± 20%
nominal speed	rpm	3000	3000	
nominal current	ADC	3,5 / 1,8	5,3 / 2,7	
nominal power ^{2) *)}	W	53	90	
operation acc. to VDE 0530		S1		
protection acc. to VDE 0530		IP 54		
rotating direction		reversible		
structural shape acc. to VDE 0530		IM B5 - with alignment by end plate		
kind of connection		connectors (see below)		
mechanical data:				
moment of inertia motor	kgm ²	0,005*10 ⁻³	0,009*10 ⁻³	
nominal torque ^{2) *)}	Nm	0,17	0,28	
peak torque ^{*)}	Nm	0,34	0,56	
speed regulation constant	N ⁻¹ cm ⁻¹ rpm	65	27	
mechanical time constant	ms	5,5	3,5	
friction torque	Nm	0,015	0,02	
rotor weight	kg	0,12	0,19	
total weight	kg	0,72	1,0	
ball bearings	A/B-side	609/608	609/608	
F _R (allowable radial shaft load) ³⁾	N	50	50	
F _A (allowable axial shaft load)	N	20	20	
electrical data:				
number of phases		3	3	
number of poles		6	6	
terminal resistance ⁴⁾	Ω	0,5 / 1,8	0,31 / 1,20	
inductance ⁴⁾	mH	0,26 / 0,90	0,22 / 0,84	
voltage constant ^{1) *)}	V/1000 rpm	3,0 / 5,9	3,8 / 7,4	
torque constant ^{1) *)}	Nm/A	0,025 / 0,049	0,031 / 0,061	
electrical time constant	ms	0,5	0,7	
thermal data:				
max. ambient temperature	°C	40	40	
isolation acc. to VDE 0530		F	F	
thermal time constant	min	10	12	
temperature-rise n.v.	K/W	2	1,7	
parking brake:				
static brake torque	Nm	1	1	automatically activated
power	W	10	10	
mass moment of inertia	kgm ²	0,0021*10 ⁻³	0,0021*10 ⁻³	
motor weight incl. parking brake	kg	0,95	1,25	
signal interfaces:				
analogue input	AE1	± 10V, 10Bit, Ri=20kOhm		setpoint setting
digital inputs	DE1... DE3	0,0V ≤ Uoff ≤ 5,0V 15,0V ≤ Uon ≤ 30V		DE1 = enable DE2/3 = function configurable
digital outputs	DA1 DA2	24V, 50mA, o.C.		function configurable e.g. ready, speed indication... also to be used as an input
serial interfaces	RS232	9600Baud		for „DserV“ software communication
	CAN	max. 800kbit/s, ISO11898		CANopen, DeviceNet (optional)
connectors:				
angled connector, rotatable 300°		Serie 615 ytec / itec (INTERCONTEC)		

*) Tolerance - 10 %

1) Sinusoidal-peak

2) Values are for motor-assembling on a locating face of aluminium of at least 0,15 m² at a thickness of 10 mm or similar metal face.

3) Middle of the shaft-extension.

4) Measured between two phases.

order code:

HBI 22XX - X X X

— B = with parking brake

— A = analogue setpoint (itec single connector)

— C = CANopen interface

— I = incremental output 1024pulses per rev. A,B,Z RS422

— 2 = 24VDC operation voltage

— 4 = 48VDC operation voltage

— 30 = HBI 2230 / 53W / 0,17Nm

— 60 = HBI 2260 / 90W / 0,28Nm

Accessoires (optional):

- connecting cable supply / signals assembled 2m / 5m

- connecting cable CAN assembled 6m

- connecting cable incremental signals assembled 5m